

**PALFINGER**

EPSILON TIMBER & RECYCLING CRANES



M160H  
Harvester

# M160H100

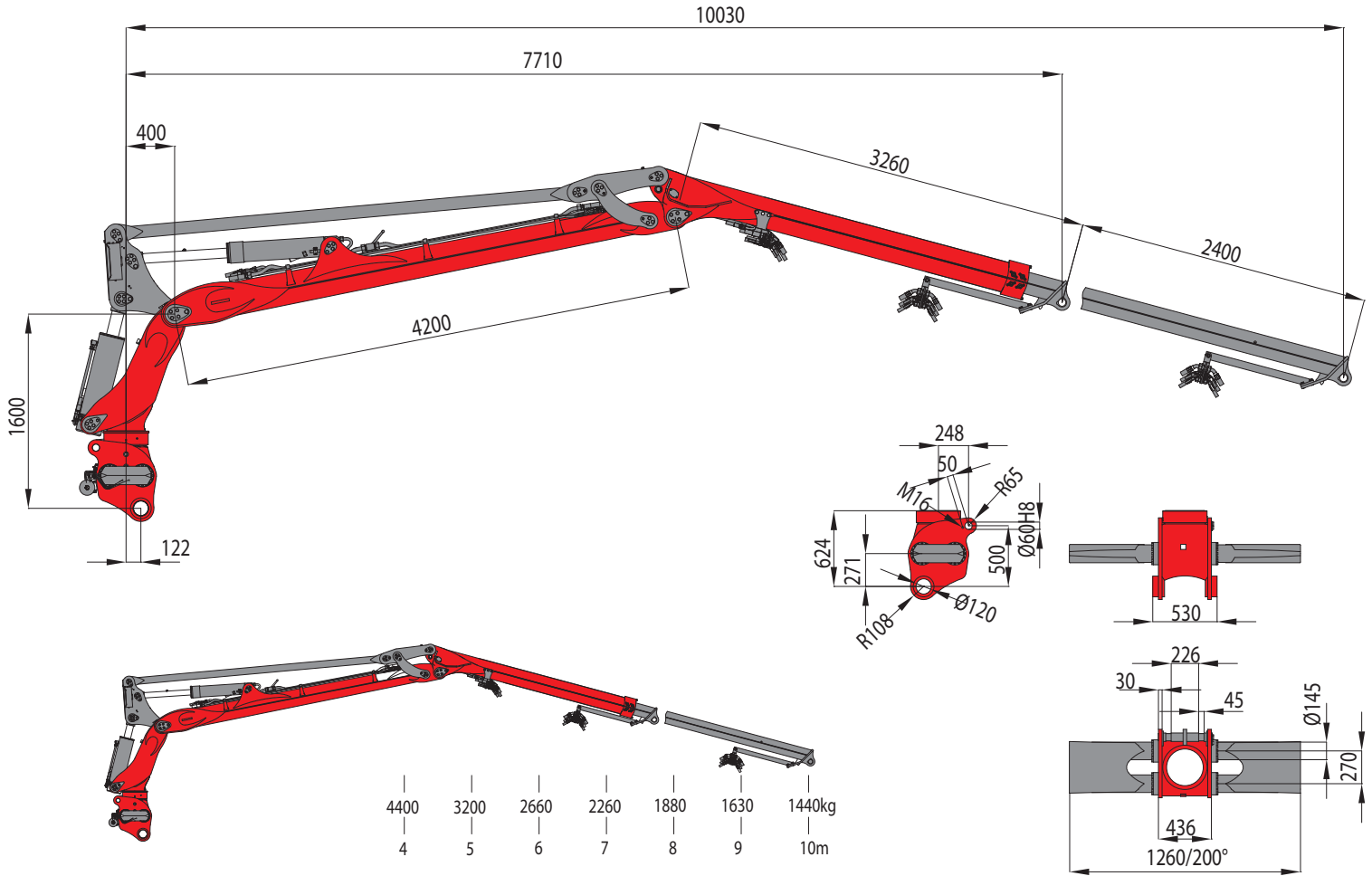

# M160H100EP

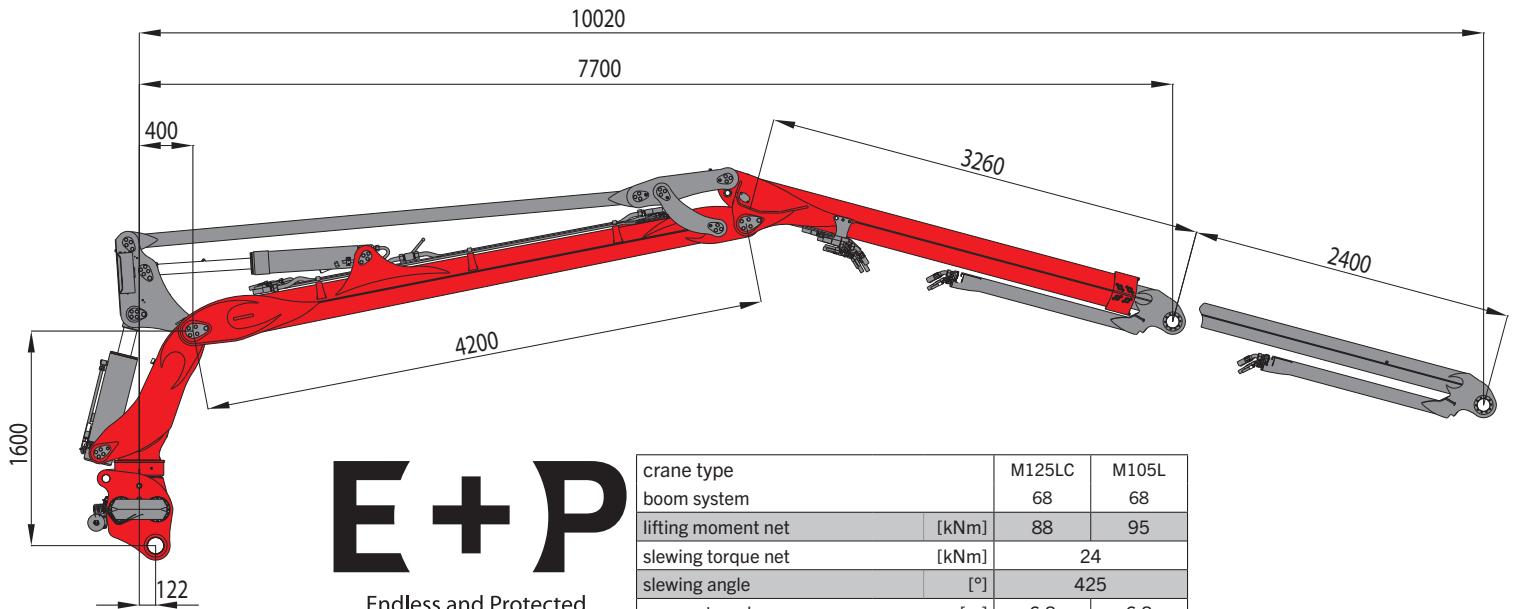

**E+P**  
Endless and Protected

crane type		M125LC	M105L
boom system		68	68
lifting moment net	[kNm]	88	95
slewing torque net	[kNm]	24	
slewing angle	[°]	425	
max. outreach	[m]	6,8	6,8
operating pressure	[bar]	260	
rec. pump capacity	1K [l/min]	1x 60-70	
dead weight	[kg]	1830	1990